



DZY SERIES DIESEL PANEL USER GUIDE



*We manage water.
You can use it safely.*

***MADE IN
TÜRKİYE***



ATTENTION PLEASE!

CONTROL PANELS, TO GET THE BEST RESULTSTHIS MANUAL
INFORMATION MUST READ CAREFULLY. THIS MANUAL,
ALL YOUR PROBLEMS CAN HELP SOLVE

THIS USER'S GUIDE :

Control panel use the correct and safe is to help.

- Control panels installation , startup and maintenance operations contains.
- Control panels transport storage and describes the terms of guarantee.
- Control panels read the instructions before using.
- Especially obey the safety instructions.
- Control panels all transactions must be done by qualified personnel in accordance with the user guide instructions.
- All repair and processing warranty made by unauthorized persons terminates.

Within Easy Reach Of The Clipboard User Guide Near And Place Should Be

PLEASE REMEMBER TO STORAGE

SAFETY INSTRUCTIONS



This symbol "personal threat" is used to warn you about.



This symbol "dangerous voltage" is used to warn you about.

1 :Read instructions carefully before starting the clipboard.

2 :Follow the instructions in the user guide.

3 :The front panel be careful. The front panel fragile gets hit

4 :Do not install where water can take directly to the clipboard. Any water in the cabinet and Do not spill liquid.Disconnect power the main fuse in the case of water in panel contact the please institutions and authorized person.

5 :Do not operate if any foreign substance enters into the panel. this may cause electric shock or damage to the panel. Entrust panel control by authorized personnel.

6 :Fire risk avoid naked flame Keep away from flammable liquids and materials.

7 :Electrical connection as shown in the user's guide input must be connected to the fuse. Otherwise you may cause serious injury or death as a result of electric shock.

8 :The power cord is damaged, replace the original with the appropriate new cable through authorized service.

9 :Do not use electrical connection cable damaged and torn. Do not place heavy objects on the power cord, and do not make an operation on the cable or injure.Cables may be damaged and may cause a fire or electric shock. In such cases, please contact the authorized person or institutions.

10:See the troubleshooting section in Troubleshooting and fault finding practice immediately and call service if necessary. Never attempt to repair this dashboard.

11:Do not dispose of together with general household waste your clipboard. Please observe local laws and regulations for disposal.

Failure to follow the safety instructions, will void the product warranty.

Situations That May Be Harmful For Human And Environmental Health Warnings :

Installation, commissioning and service procedures performed by qualified personnel as long as the board is does not constitute a security risk to any.



* Burns, electric shock, and death may result.

* Disconnect the electrical connections to the panel before working on them.



* Please do the clipboard the grounding connection.

* Relaxation of the electrical connections and electrical leakage may cause injury.

👉 Panel manual starting and stopping methods have been described.

👉 During the re-commissioning of the panel, the departments should operate on.

👉 "leakage relay" Should be, possible water leaks and "splashes clipboard against must installed.

👉 All electrical wiring must be connected to the clipboard using the protective cover.

Unacceptable Actions :

On the control panel of design changes must be with made not only the permission of the manufacturer. Control panels are used on the other parts, the manufacturer is not responsible for the consequences of changes.

On The Control Panel The Special Security Equipment And Recommendations :



May result in electrical shock or death.



In the wrong intervention to the control panel may cause damage to the panel.

Control panel electronic card in order to protect from external factors is made of plexiglass with a specially designed insulation protection is available.

This protection panels and electronic card intervene must not removed by unauthorized persons.

Efficient Use of Energy Saving Information :

Pumps and motors energy-consuming products.

Personal causes and is extremely important for the national economy.

Control panel suitable motor and pumps be used.

All electrical connections to the instructions by providing appropriate and accurate; Be provided to prevent any loss and leakage of electricity.

Usage Life :

The product is determined by the Ministry of Industry and declared usage life (time required to carry out the functions of the appliance spare parts) 10 years.

TRANSPORT / STORAGE / MONTAGE

Transport :

Handle carefully control panels

Appropriate size of the control panels are shipped in cardboard boxes.

Do not remove the cardboard box inside the control panels during transport.

measure damage to the panel, and bad weather conditions during transport should be taken to avoid exposure.

Received by the panel in order to comply with the model and should be checked for any damage during transport.

If the clipboard contains a damaged or missing damage assessment report should be given written information to the shipping company our company.

Storage :

Control panels of instead of immediately montage if not ;

Do not store in damp environments.

Do not put weight on the control panels.

Protect from direct sunlight at the control panels.

Keep out of the control panels watertight.

Montage :



When performing mounting, follow the instructions otherwise it may be damaged panels



Montage are not observed instructions during the that as a result of electric shock, serious injury or death may result.

While mounting nuts at the rear of the control panel should be mounted with suitable screws.

Do not mount the back of the board is drilled with another screw. This may cause damage to the electronic card.

Control panel electrical connection must be carried out only by qualified personnel necessary safety precautions.

OPERATING

Control panel electrical connections should be checked.

The control panel should be checked that the cover is closed.

There is power cut, the phases should be checked to be complete.

Control panel settings to be used should be based on pump or motor.

Introduction to the settings menu, you will find that you are using the appropriate settings to the clipboard.

MAINTENANCE

Monthly Maintenance :



Disconnect electrical power before maintenance operations.

Control panel electrical connections should be checked relaxation .

The grounding line of the control panel should be checked.

electric cables, abrasion, puncture should be examined for color change and warming.

General Information

- *Microprocessor based design.*
- *64Mhz operating frequency.*
- *128 Kb Program memory.*
- *3936 byte SRAM*
- *1024 byte EEPROM.*
- *1.000.000 read/write data capacity.*
- *100 years data retention life.*
- *Design with nanowatt technology.*
- *128x64 pixel graphic screen.*
- *Password protection.*
- *Maintenance settings menu.*
- *Programmable digital input.*
- *Programmable battery selection.*
- *Programmable starter cut setting.*
- *Measuring the temperature value.*
- *Measuring the oil pressure value.*
- *Measuring the fuel value.*
- *Ability to limit the number of starter.*
- *Low battery (charge fault) reporting.*
- *Measuring battery voltage values and displaying on the screen.*
- *Diesel revolution (RPM) measurement.*
- *Reel time clock.*
- *Select of closed-open type pressure switch.*
- *Starting the pump with remote start.*
- *Possibility to set error delay time.*
- *Auto Manual selection switch.*
- *Past 50 fault records*
- *Reel time clock automatic test.*
- *Automatic test solenoid valve output.*
- *Exchanger (cooling) outlet.*
- *Adjustable stop delay time.*
- *Memorizing the commissioning date.*
- *Turkish English language support.*
- *Ability to display running time on the screen*
- *Ability to display number of switchgear.*
- *Ability to monitor working hours on the screen*
- *Ability to use with pressure transmitter*
- *Ability to see the pressure value.*
- *Adjustment of set pressure value.*

FRONT PANEL DESCRIPTION AND USE

Pump Control System

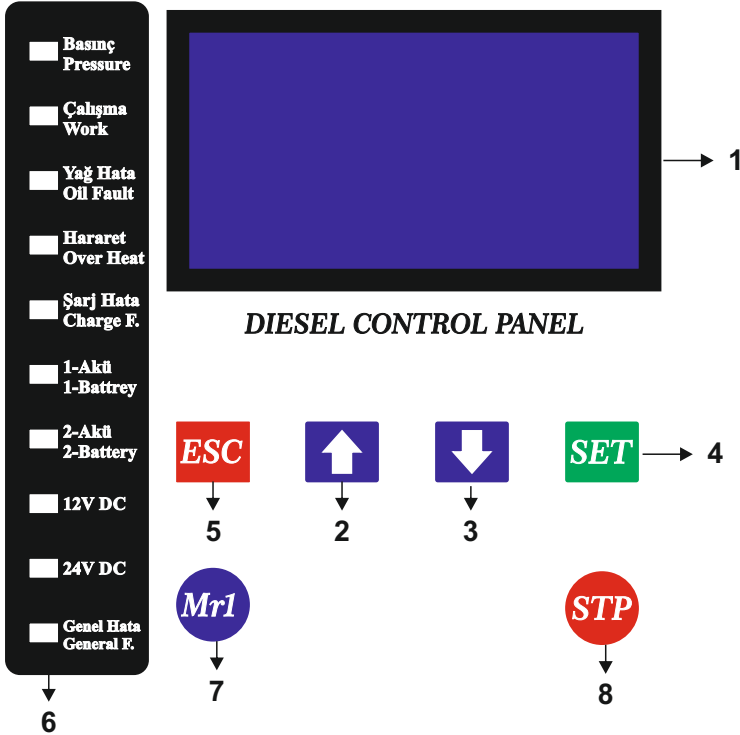

1 : 128X64 graphic screen.

2 : Up arrow key to move up in the menu on the main screen and provides paging

3 : Down arrow key to move down in the menu provides.

4 : Set key to enter the menu and used the changes made in the menu.

5 : ESC key to return to the menu and the menu before a transaction is allowed to rise.

6 : Status Leds.

7 : Manual start button.

8 : Manual stop button.

SETTINGS MENU



press the **SET** button to enter the menu.



Authorized password to enter the setup menu screen comes up, press the SET button and the display 1 starts to blink up and down with the arrow keys and the password is set to step 1 SET button is pressed until 1st digit is fixed and 2 H starts to blink. 2 value up or down arrow is set with the keys and the SET button is pressed. The same process is repeated for the 3rd and 4th digits. Password is incorrect Incorrect Password message is received on the screen. Press the SET button to enter the password again. If the password is correct income the following screen.

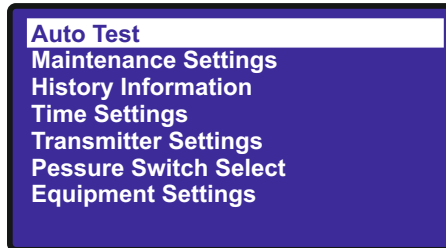

After entering the correct password, the main screen will be as seen above.

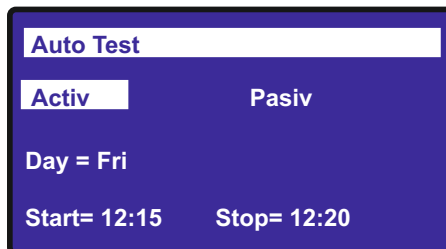

If automatic test is selected active, first the test day is selected and saved with the set button. The screen passes the start time setting part, and the desired time is set with the up and down arrow keys.

SETTINGS MENU

Maintenance Settings

Maint Hour : 100
Maint Date : 24/04/23
Running Hour : 000:00
Rmng. Hour : 100

Maint Hour : Maintenance time setting. After the diesel engine runs for the time set here, a maintenance warning is displayed on the screen.

Maint Date : Maintenance date. The system automatically delays the time by one year each time a maintenance is performed.

Running Hour: Diesel engine running time is displayed.

Running Hour: Remaining operating hours for maintenance are displayed.

History Information

01: Diesel Stop

The device memorizes the last 50 event records and is displayed on this screen.

Time Settings

Stop Delay : 100
Stop T. : 10 Hold T.:04
Start delay : 03
Mars Time : 06
Batry Time : 10

SETTINGS MENU

Stop Delay : Diesel stop delay time setting.

Stop T. : Stop solenoid is the time setting.

Hold T. : Stop solenoid hold is the time setting.

Start Delay : Pressure switch is the delay time.

Mars Time : Is the starter coil time setting.

Batry Time : It is the waiting time setting for 2st starters.

Transmitter Settings

Activ

Set Value = 08.0

Hys Value= 00.5

Max Value= 16

Set Value : Diesel engine stop set pressure value.

Hys Value : Pressure hysteresis adjustment. For example, if our set pressure is 8.0 bar hysteresis 1.0, then the system starts to operate at 7.0 bar.

Max Value : Pressure transmitter maximum (label) value 16 bar Set sensor value 16 bar.

Note: If the transmitter option is selected as active, pressure switch connection is not required.

Pressure Switch Selec

Closed

Open

Closed : Closed type pressure switch usage selection.

Open : Open type pressure switch usage selection.

SETTINGS MENU

Equipment Settings

Oil Sensor
Temp. Sensor
RPM Sensor
Fuel Sensor
Input Set

Oil Sensor : Diesel oil sensor active and passive select. If active is selected, maximum oil pressure protection is set.

Temp. Sensor : Diesel temperature sensor active and passive select. If active is selected maximum temperature protection is set.

RPM Sensor : Diesel rpm sensor active and passive select. If active is selected maximum and minimum rpm protection is set.

Fuel Sensor : Diesel fuel sensor active and passive select. If active is selected, fuel status can be monitored on the screen.

Input Set : Is the panel input protection setting. floater etc. Protection is done with an extra input.

Date Settings

Date : 25/04/22 Mon
Hour : 15:32

Date and time setting menu. Date and time can be set with the up and down arrow keys and saved by pressing the set key.

Modbus RTU

ID No : 001
Baud Rate : 9600
Parity : 1

ID No : It is the number of the device in the communication system.

Baud Rate : Communication speed setting.

Parity: Number of stop bits.

CONNECTION DIAGRAM

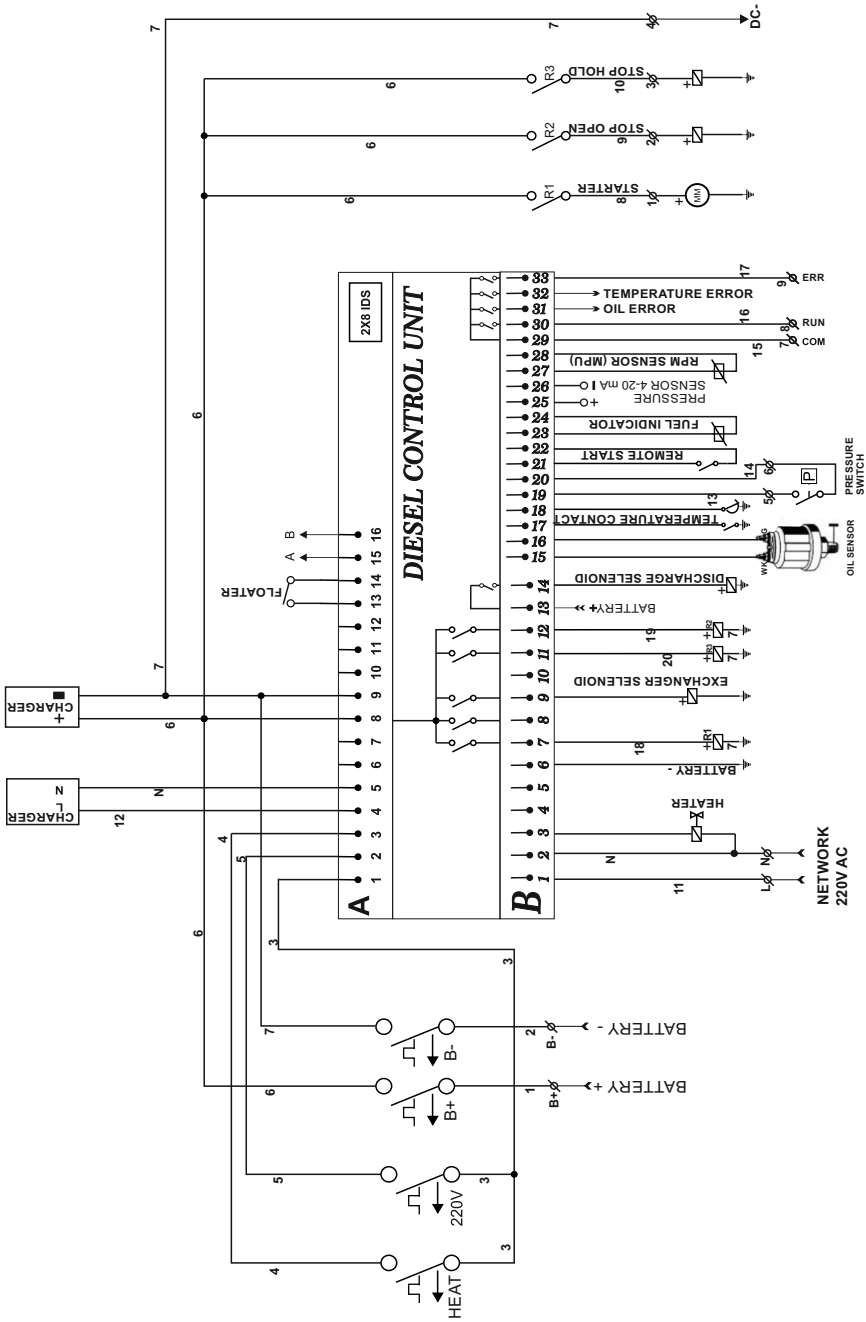

WARRANTY

Principles specified in this user guide, instructions, standards-compliance No other institution and contact an authorized service maintenance, repair or other reasons, provided that untreated The materials used on the control panel manufacturer; workmanship, assembly and manufacturing defects user Company is subject to the terms of warranty.

Outside the Remaining Extent of Warranty Conditions :

1. Warranty terms and conditions only on the invoice in writing the product / products covers.
2. User errors, failures and damages that occur.
3. Misuse damages use and malfunctions.
4. Incorrect installation, incorrect or incomplete damage and faults caused from installation made
5. Shipping, vibration, storage, physical collisions, damage and malfunction caused by chemical factors, and environmental conditions.
6. Fire, lightning, floods, earthquakes and other natural disasters damage and malfunctions.
7. Failures and damages caused intentionally harming.
8. Incompatibility or lack of damage to the cables used in electrical installations and faults.
9. In the Product's user guide for damage and malfunctions occurring against the issues.
10. The interventions given to the product by unauthorized persons to the product warranty expires.

CAUTION

Please obey this user guide and following subjects for safety use.

- All energy should be cut-off while device connecting to panel.
- Solvent or similar matter use when cleaning.
- Check the connections according to connection diagram.
- Defective device should repair only producer company or authorized seller.

!!! The company or authorized seller is not responsible for bad result which born of these unperformed conditions.

TECHNICAL DETAILS

Operating Voltage (Un)	230V – 12/24V DC
Operating Frequency	50/60Hz.
Working Power	<10VA
Operating temperature	-20°C to 55°C
Voltage Measurement Range	10-500V AC
Measurement Accuracy	%±1
DelayTime setting	1-30 sec.
Indicator	128X64 pixel LCD and leds
Connection style	Terminal connection
Ignition	5A/250VAC Resistive Load
Connection Insulation	2.5kV
Assembly	On the pump or on the wall
Protection Class	Ip55
Working Altitude	<2000meter

QUALITY CERTIFICATES



CERTIFICATE Attestation of Conformity

Name and Address of Certificate Holder:
KIK ELEKTRIK INŞ. TİC. SAN. VE TİC. LTD. ŞTİ. Sarıyer Mah. Çiğdem Sok. No:1 Paralı / İSTANBUL

Certificate Number:
SE-228-09-100221

Name and Address of Manufacturer:
KIK ELEKTRİK INŞ. TİC. SAN. VE TİC. LTD. ŞTİ. Sarıyer Mah. Çiğdem Sok. No:1 Paralı / İSTANBUL

Date of Issue:
25.04.2022

Brand:



Expiry Date:
22.04.2023

Product Name:
Pump Controller Panel

Test Report Number:
19 1266 80 N01 01: LVD-228-02811-D

Model No:
DZ-02, DL-01, DL-01, DZ-0P, 8DY-01, DZ-01, DZ-02

Page:
1 of 1

Test Required:
EN 62368-1:2015; EN 61000-6-1:2007; EN 61000-6-3:2007/A1:2011/AC:2012

This product meets the technical requirements of the above standards as mentioned in the reference test reports and hence fulfils the technical requirements of the following directives:

**2014/30/EU Electromagnetic Compatibility Directive
2014/35/EU Low Voltage Directive**

This certificate is only valid for the equipment and configuration described in our brochure with the seal. Additional equipment or other accessories are not covered by it. The above referenced standards refer to the current version of the standard.

The CE Mark is a mere compliance statement, under the responsibility of the manufacturer, of the product after comparison with EC Declaration of Conformity and compliance with relevant EC Directives.





DIGİTAL İMZA VE MÜHÜR KURULUŞU
 SİGEMER
 www.sigemerkurulusu.com



CERTIFICATE Attestation of Conformity

Name and Address of Certificate Holder:
KIK ELEKTRİK INŞ. TİC. SAN. VE TİC. LTD. ŞTİ. Sarıyer Mah. Çiğdem Sok. No:1 Paralı / İSTANBUL

Certificate Number:
SE-228-09-100221

Name and Address of Manufacturer:
KIK ELEKTRİK INŞ. TİC. SAN. VE TİC. LTD. ŞTİ. Sarıyer Mah. Çiğdem Sok. No:1 Paralı / İSTANBUL

Date of Issue:
25.04.2022

Brand:



Expiry Date:
22.04.2023

Product Name:
Pump Controller Panel

Test Report Number:
LVD-228-02811-D

Model No:
Y.NRPAD1EJL035 (ABC s06 Annex B)

Page:
1 of 2

Test Required:
EN 60204-1:2018

This product meets the technical requirements of the above standards as mentioned in the reference test reports and hence fulfils the technical requirements of the following directives:

2014/35/EU Low Voltage Directive

This certificate is only valid for the equipment and configuration described in our brochure with the test acts, detailed control documents and technical data with compliance with the above referenced applicable legal provisions for the product.

This CE Mark is a mere statement of compliance, under the responsibility of the manufacturer or the customer, after comparison with EC Declaration of Conformity and compliance with relevant EC Directives.





DIGİTAL İMZA VE MÜHÜR KURULUŞU
 SİGEMER
 www.sigemerkurulusu.com



DZY SERIES DIESEL PANEL USER GUIDE



*We manage water.
You can use it safely.*

***MADE IN
TURKEY***