

PANO TİPİ : NFPA-20 ELEKTRİKLİ YANGIN PANOSU

PANEL TYPE : NFPA-20 ELECTRICAL FIRE PANEL

TEKNİK BİLGİ (TECHNICAL INFO)

POMPA SAYISI (PUMP NUMBER) : 1
POMPA GÜCÜ (PUMP POWER) :kW
POMPA AKIM (PUMP CURRENT) :A
VERSİYON (VERSION) : K.2.5.16-1

BESLEME GERİLİMİ (SUPPLY VOLTAGE) : 3X400 V / 230 V 50-60 Hz. AC , PE
ÇALIŞMA SICAKLIĞI (RUN HEAT) : -20 / +50c
KORUMA SINIFI (PROTECTION CLASS) : IP 55

PANO KODU (PANEL CODE) :

Y.NFPA01E/YU70	Y.NFPA01E/YU75
Y.NFPA01E/YU11	Y.NFPA01E/YU90
Y.NFPA01E/YU15	Y.NFPA01E/YU110
Y.NFPA01E/YU18	Y.NFPA01E/YU132
Y.NFPA01E/YU22	Y.NFPA01E/YU160
Y.NFPA01E/YU30	Y.NFPA01E/YU185
Y.NFPA01E/YU37	Y.NFPA01E/YU200
Y.NFPA01E/YU45	Y.NFPA01E/YU250
Y.NFPA01E/YU55	Y.NFPA01E/YU315
	Y.NFPA01E/YU400

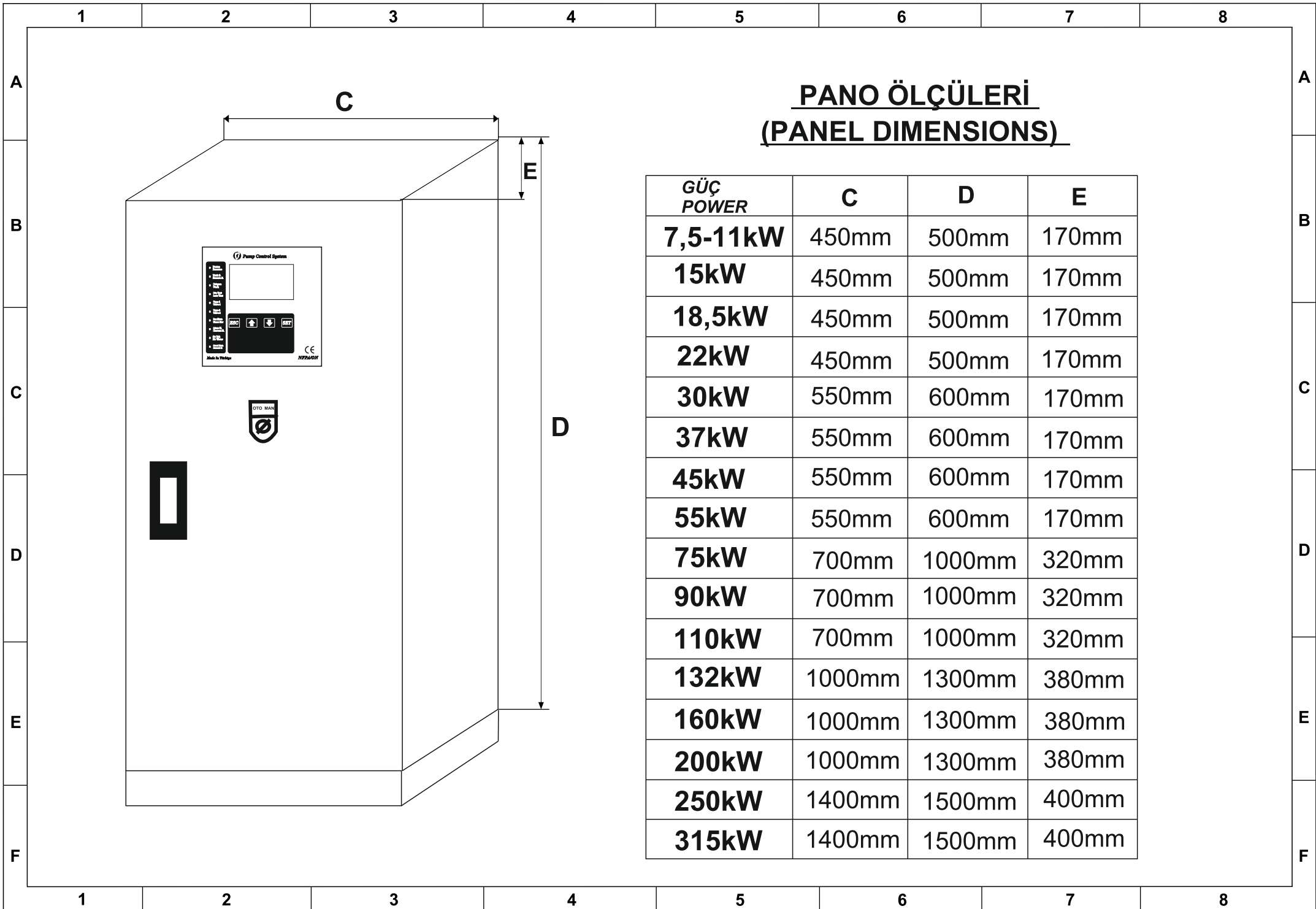

PANO ÖLÇÜLERİ
(PANEL DIMENSIONS)

<i>GÜÇ POWER</i>	C	D	E
7,5-11kW	450mm	500mm	170mm
15kW	450mm	500mm	170mm
18,5kW	450mm	500mm	170mm
22kW	450mm	500mm	170mm
30kW	550mm	600mm	170mm
37kW	550mm	600mm	170mm
45kW	550mm	600mm	170mm
55kW	550mm	600mm	170mm
75kW	700mm	1000mm	320mm
90kW	700mm	1000mm	320mm
110kW	700mm	1000mm	320mm
132kW	1000mm	1300mm	380mm
160kW	1000mm	1300mm	380mm
200kW	1000mm	1300mm	380mm
250kW	1400mm	1500mm	400mm
315kW	1400mm	1500mm	400mm

3/N,PE,50Hz. 380/220V AC.

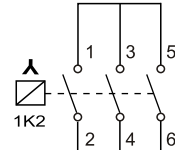
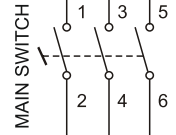
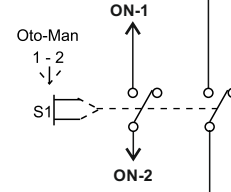
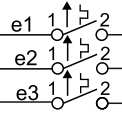

NFPA Series Control Unit
NFPA-I/O **CE**

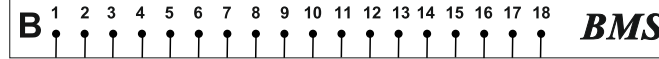

X1 L1 L2 L3 N PE

X1 U V W PE X Y Z



POMPA

L1 L2 L3 N PE
ENERJİ GİRİŞİ

**PANOYA MUTLAKA
TOPRAKLAMA YAPINIZ**

R
DIESEL
CHARGE
N

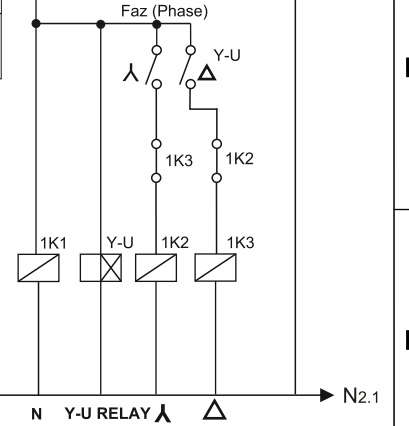

ÜRÜN KODU	ÇİZEN	KONTROL	KORUMA	TARİH
KRK-3730011	Y.BULBUL	Z.KARAKAYA	IP-54	11.10.2018
KRK ELEKTRİK İNŞ.TURZ SAN VE TİC. LTD.ŞTİ	İLETİŞİM www.krkelektrik.com		SAYFA 1	
1 POMPA YANGIN PANOSU				

BAĞLANTI ŞEMASI

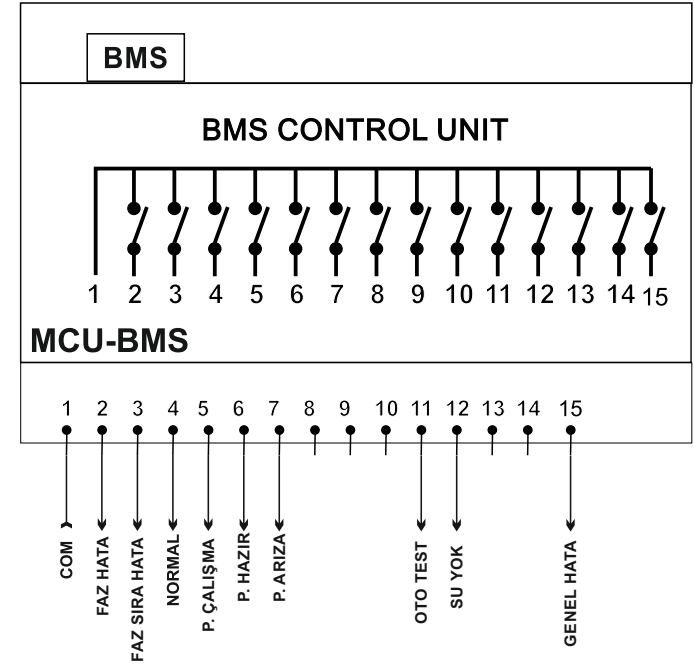
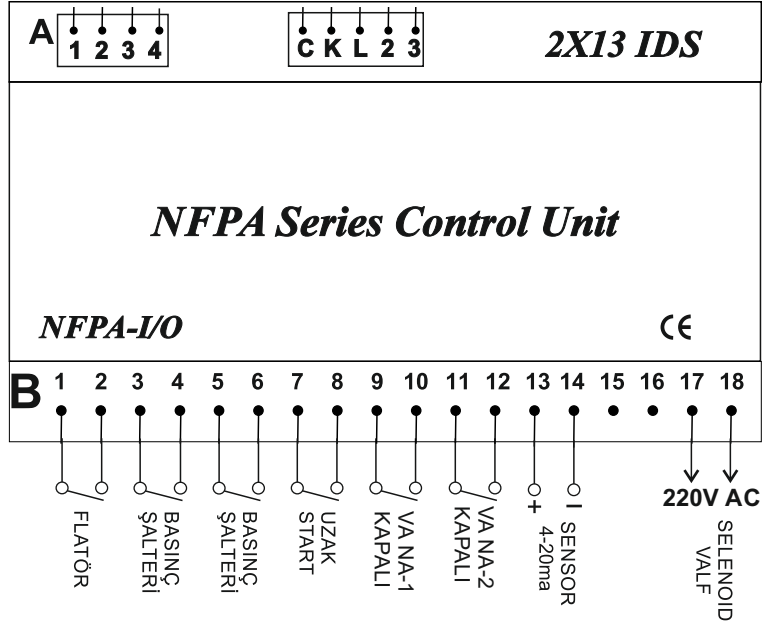

CONNETTION DIAGRAM

